

use & care guide

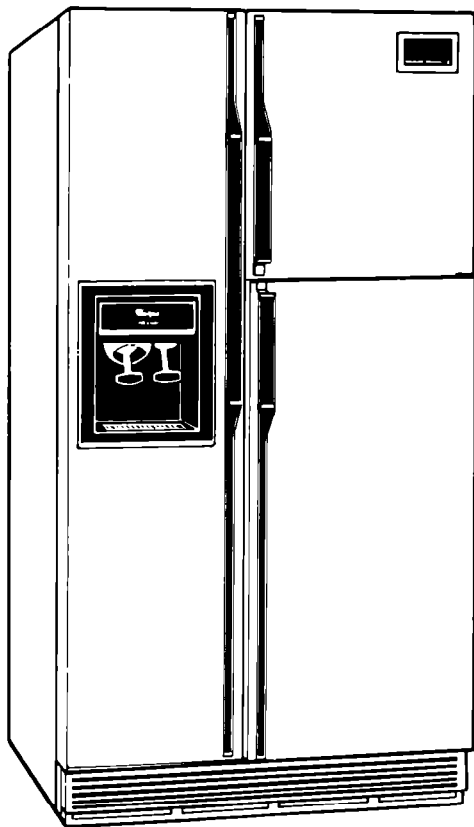

NO-FROST REFRIGERATOR- FREEZER

Model ED26SS

ers. Freezers. Refrigerator-Freezers. Ice Makers. Dishwashers. Built-In Ovens and Surface Units. Ranges. Microwave Ovens. Trash Compactors. Room Air Conditioners. Dehumidifi

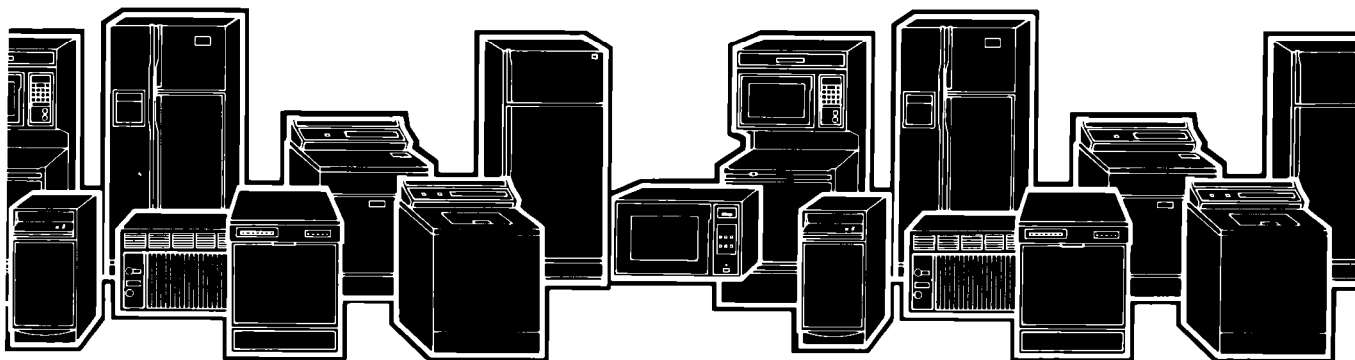

Please read this Use and Care Guide before you do anything else...

This booklet tells how to start your refrigerator, clean it, move shelves and adjust controls. It even tells you what to do if **symbols** appear on the Performance Control Package and if unfamiliar sounds are heard.

Treat your new refrigerator with care. Use it only to do what home refrigerators are designed to do.

Parts and features

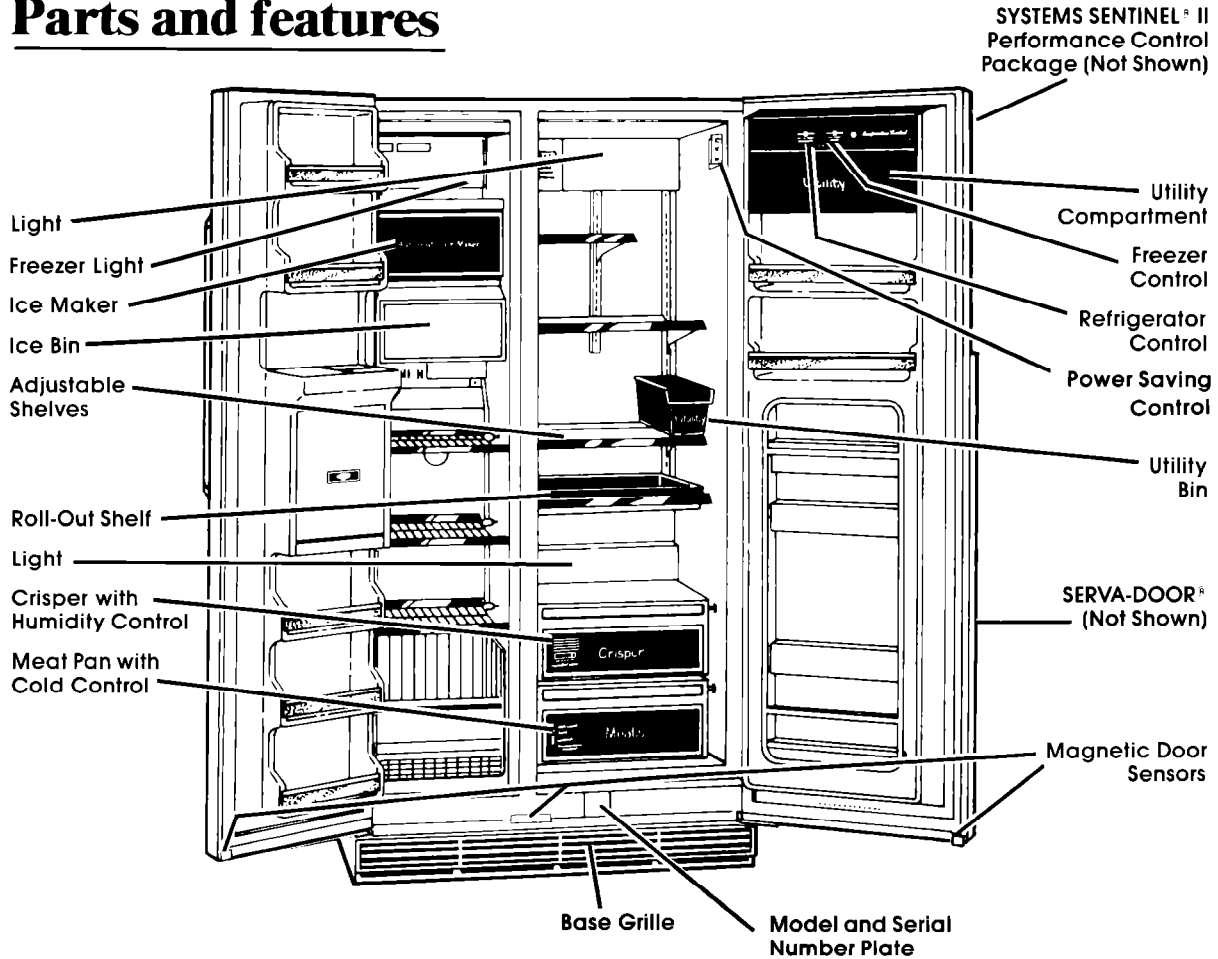

Copy your Model and Serial Numbers here...

When you need service or call with a question, have this information ready:

1. Complete Model and Serial Numbers (from the plate located as shown).

2. Purchase date from sales slip.

Copy this information in these spaces. Keep this book, your warranty and sales slip together in a handy place.

Model Number

Serial Number

Purchase Date

Service Company and Telephone Number

Safety first

Child entrapment, and suffocation, are not things of the past. Junked or abandoned refrigerators are still dangerous...even if they will "just sit in the garage for a few days."

If you are getting rid of your old refrigerator, do it safely. Please read the enclosed safety booklet from the Association of Home Appliance Manufacturers. Help prevent accidents.

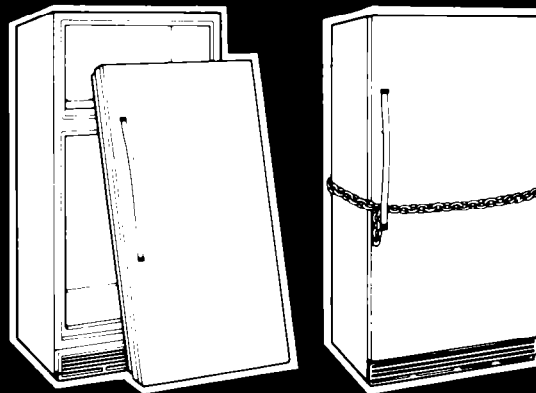

BEFORE USING

PARTS AND FEATURES

Contents

	Page		Page
BEFORE YOU PLUG IT IN	3	Covers	9
Install Properly	4	Removing the Freezer Shelves	10
Level Refrigerator-Freezer	4	Removing the Freezer Basket	10
Remove Sales Labels	4	Cold Water and Ice Dispenser	10
Clean It	4	Common Problems	10
Plug It In	4	Removing the Storage Bin	11
USING YOUR REFRIGERATOR	5	The Night Light	11
Setting the Controls	5	Changing Light Bulbs	11
Changing the Control Settings	5	Sounds You May Hear	12
Power Saving Control	5	Energy Saving Tips	12
SYSTEMS SENTINEL® II Performance		CLEANING YOUR REFRIGERATOR	12
Control Package	6	Removing the Base Grille	12
The Check Point Display	6	Cleaning Chart	13
The Temperature Displays	6	FOOD STORAGE GUIDE	14
The Control Pads	6	Storing Fresh Food	14
Reading the Performance Control		Freezing and Storing Frozen Foods	15
Package	7	VACATION AND MOVING CARE	18
Adjusting Meat Pan Temperature	8	IF YOU NEED SERVICE OR ASSISTANCE	19
Adjusting Crisper Humidity Control	8	1. Before Calling for Assistance	19
Adjusting Shelves	9	2. If You Need Assistance	19
Removing the Roll-Out Shelf	9	3. If You Need Service	19
Removing the Crisper, Meat Pan and		4. If You Have a Problem	19

©1985 Whirlpool Corporation

Before you plug it in

IMPORTANT

Before using your refrigerator, you are personally responsible for making sure that it...

- is installed and leveled on a floor that will hold the weight, and in an area suitable for its size and use.
- is connected only to the right kind of outlet, with the right electric supply and grounding. (See page 4.)
- is used only for jobs expected of home refrigerators.
- is not near an oven, radiator or other heat source.
- is properly maintained.
- is out of the weather.
- is used in an area where the room temperature will not fall below 60°F (16°C).
- is not run where there are explosive fumes.
- is not used by children or others who may not understand how it should be used.
- is not loaded with food before it has time to get properly cold.

Install properly...

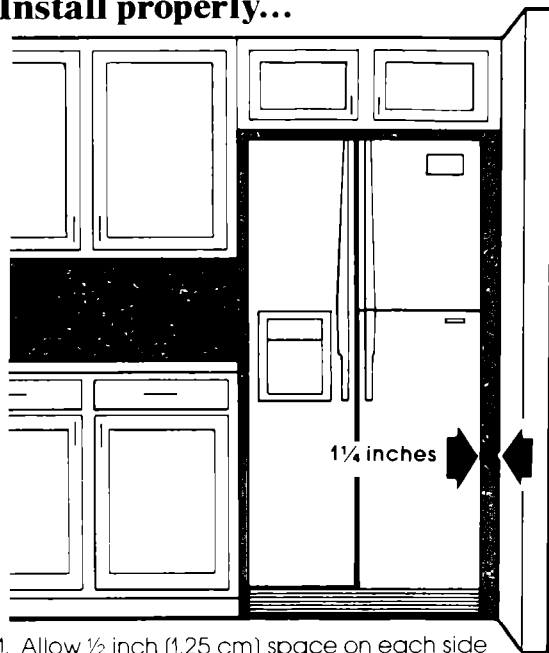

1. Allow 1/2 inch (1.25 cm) space on each side and at top for ease of installation.
2. The refrigerator back can be flush against the wall.
3. If the refrigerator is to be in a corner, keep 1/4 inches (3.1 cm) between the wall and side of the refrigerator so there is room to open the small access door on your SERVA-DOOR® refrigerator or to clear the ice and water dispenser.

Level refrigerator-freezer...

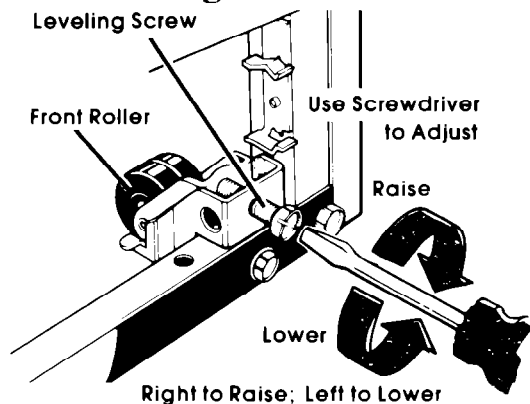

1. Remove base grille (see page 12).
2. To raise front, turn each screw to the right.
3. To lower front, turn each screw to the left.
4. Check with level.

Remove sales labels...

Remove the Consumer Buy Guide label, tape and other non-instructional **inside** labels. Any remaining glue can be removed by briskly rubbing with thumb – **or** – can be soaked with dishwashing detergent solution, then rubbed with thumb.

DO NOT USE rubbing alcohol or flammable or toxic solvents, such as acetone, gasoline, carbon tetrachloride, etc. These can damage the material.

NOTE: DO NOT REMOVE The two labels inside the Utility Compartment. They are permanent instructions for using the **SYSTEMS SENTINEL® II Performance Control Package**.

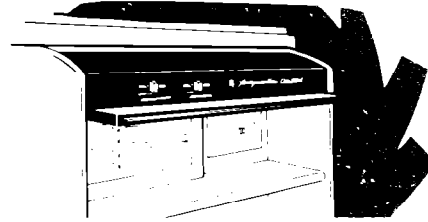

Clean it...

Clean your refrigerator before using it. See cleaning instructions on page 12.

Plug it in...

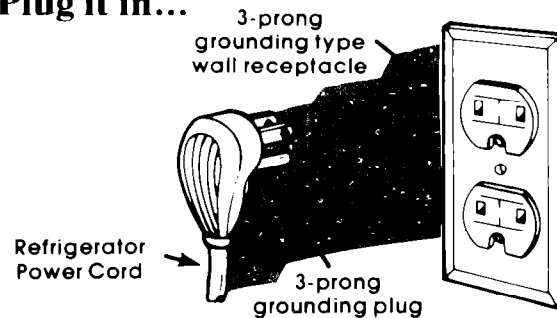

RECOMMENDED GROUNDING METHOD

A 115 Volt, 60 Hz., AC only, 15 or 20 ampere fused and grounded electrical supply is required. It is recommended that a separate circuit serving only this appliance be provided.

Do not use an extension cord. Use a receptacle which cannot be turned off with a switch or pull chain. See individual electrical requirements and grounding instruction sheet in your literature package.

When you plug in the refrigerator...

- Symbols on the Performance Control Package will glow.
- You may even hear a soft beeping sound (8 beeps every 2 minutes). This is normal.

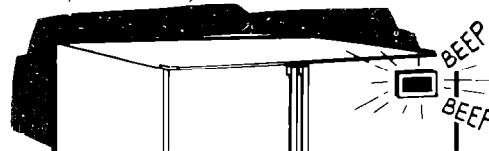

To stop the beeping:

- Touch and **hold** the RESET/TEST Pad until you hear 2 beeps. The Control Package "TEST" Light will come on underneath the "OK" Light.

When the refrigerator has cooled, reset the Control Package for scanning by touching the RESET/TEST Pad. You will hear a beep, and the "TEST" Light will go off. This tells you the refrigerator is in its monitoring operation. (See page 6 for more information on the **SYSTEMS SENTINEL® II Performance Control Package**.)

Using your refrigerator



Setting the controls...

The Refrigerator Control and the Freezer Control are located on the top inside of the right door. When the refrigerator is first plugged in, both of these controls should be set in the middle, as shown above.

Give the refrigerator time to cool down completely before adding food. (This may take 24 hours.)

Do not block the air outlet near the lights. Blocking it can slow the air movement needed to keep temperatures at the level you set.



The Temperature Display in the Performance Control Package on the front of the refrigerator door will show you when the refrigerator and freezer are cool enough for normal household refrigerator usage. (See page 6 for more information.)

The controls will be set about right when milk or juice is as cold as you like and when ice cream is firm. **If adjustment is needed, slide control slightly to get the temperature you want.** (See "Changing the control settings.")

Changing the control settings...

If you need to adjust temperatures in the refrigerator or freezer:

- Move the sliding Temperature Control Knob for that compartment only a small amount to change its temperature.
- Wait at least 24 hours between adjustments.

The Temperature Display in the Performance Control Package on the front of the refrigerator will show the temperature changes in each compartment. It is normal for the temperatures to get warmer when the doors are opened a lot or for long periods of time.



QUESTIONS?

...call your COOL-LINE® service assistance telephone number (page 49).

CONDITION:	REASONS:	RECOMMENDED SETTING CHANGE:
If Refrigerator Section and/or Freezer Section is TOO WARM:	Door opened often. Large amount of food added. Room temperature is very cold. (can't cycle often enough)	Slide the control for the section that is TOO WARM slightly to the RIGHT.
If Refrigerator Section is TOO COLD:	Control not set correctly for your conditions.	Slide the Refrigerator Control slightly to the LEFT.
If ice is not MADE FAST ENOUGH:	Heavy ice usage. Room temperature is very cold. (can't cycle often enough)	Slide the Freezer Control slightly to the RIGHT.

Power Saving Control...

The Power Saving Control, on the right, inside refrigerator wall, operates electric heaters around the door openings. These heaters help keep moisture from forming on the outside of the refrigerator.

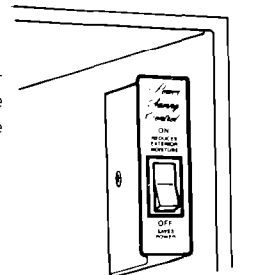

1. Use the "OFF" setting when humidity is low.
2. Use the "ON" setting if moisture forms on the outside of the refrigerator.

SYSTEMS SENTINEL® II Performance Control Package

There are three parts to the **SYSTEMS SENTINEL® II Performance Control Package**.

The Check Point Display

The Refrigerator and Freezer Temperature Displays

The Control Pads

The **SYSTEMS SENTINEL® II Performance Control** package will help you operate the refrigerator effectively and economically.

Read the following information carefully. Then keep this book in a handy place for later reference.

Instruction labels for using the SYSTEMS SENTINEL® II Performance Control Package are located inside the Utility Compartment.

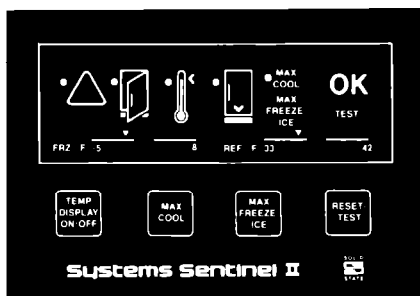

The Check Point Display

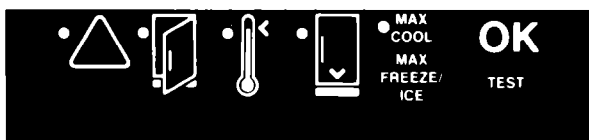

This display has symbols that glow or flash and makes a soft beeping sound for the following:

- **Lets you know** that refrigerator check points are being monitored.
- **Reminds you** to clean the condenser coils (behind the base grille).
- **Alerts you** when something is not or was not as it should be. What each symbol stands for will be covered in the following pages.
- **Indicates** when special features are being used.

The Refrigerator and Freezer Temperature Displays...



The Temperature Displays indicate the temperatures in the two compartments. These displays represent the approximate operating temperature

range of each compartment. The Arrow Signal Light in each display shows the approximate temperature. All Arrow Signal Light positions within these ranges are considered acceptable temperatures for normal operation. Displays will be black whenever the operating temperature is warmer than the acceptable temperature range. **(Note: The position of the arrow may change during normal operation.)**

The Control Pads...

Each Pad controls a special operating or monitor function for the refrigerator. Every time a pad is touched you will hear a beep.

**TEMP
DISPLAY
ON/OFF**

TEMP DISPLAY ON/OFF

Touching the TEMP DISPLAY ON/OFF Pad turns the Temperature Displays on and off. This does not affect the actual monitoring of the refrigerator and freezer compartment temperatures. It just turns out the lights behind the displays so they are not constantly visible. If the refrigerator temperatures become TOO WARM, the TEMP DISPLAY ON/OFF Pad will not work until temperatures are back within the normal operating range.

**MAX
COOL**

MAX COOL

When the MAX COOL Pad is touched, the MAX COOL Signal Light comes on and maximum cooling is provided to the refrigerator compartment for 24 hours. This is especially good for maintaining the operating temperature after adding large amounts of foods. The MAX COOL Signal Light will stay on until the 24 hour cycle is complete or is cancelled by touching the RESET/TEST Pad.

**MAX
FREEZE/
ICE**

MAX FREEZE/ICE

When the MAX FREEZE/ICE Pad is touched, the MAX FREEZE/ICE Signal Light comes on and maximum cooling is provided to the freezer compartment for 24 hours. This feature is designed to provide faster freezing and maintain freezer temperatures after adding foods to be frozen. The MAX FREEZE/ICE Signal Light stays on until the 24 hour cycle is complete or is cancelled by touching the RESET/TEST Pad.

**RESET/
TEST**

RESET/TEST

The RESET/TEST Pad is used to demonstrate or test the **SYSTEMS SENTINEL® II Performance Control Package** displays. It will erase most Check Point Display Symbols after the problems have been corrected, and cancel MAX COOL and MAX FREEZE/ICE operations. When the refrigerator is first plugged in, a touch of the RESET/TEST Pad will stop the beeping alarm until the refrigerator has reached the proper operating temperatures. (See page 4.)

To demonstrate or Test the Display, touch and hold the RESET/TEST Pad until you hear two beeps.

The Performance Control Package will show in the following order:



1. 5 seconds



2. 5 seconds



3. 5 seconds; 4 beeps

All steps will repeat as long as the TEST Light is on. The 4 beeps will only sound at the end of the first scan.

Touch the RESET/TEST Pad to return the Display to operation monitoring. A single beep will be heard.

Reading the SYSTEMS SENTINEL® II Performance Control Package...

Each symbol on the Check Point Display has a meaning. When more than one symbol glows, there is more than one message. The meaning of each symbol is still the same.



The OK Light – When the “OK” glows, refrigerator check points are OK. The scanning lights show that check points are being monitored.



DOOR OPEN Symbol – Glows when any door is open. If a door is open for more than three minutes, a beeping sound starts.

To clear the symbol and to stop the beeping sound, close the door.



TOO WARM Symbol – Means the refrigerator and/or freezer may be too warm for safe food storage. The TOO WARM Symbol and one or both of the compartment temperature displays will come on to show if the refrigerator and/or freezer are TOO WARM. You will hear a beeping sound every two minutes.

The TOO WARM Symbol may glow and a beeping may start as soon as you plug in the refrigerator. Otherwise, they will start about 1½ hours after the TEMPERATURE SENSOR detects warm temperatures. Temperatures may be warm because:

- A large amount of food is added.
- Doors are opened often (especially in warm weather).
- The power has been off for more than a few hours.
- The control settings are incorrect.

To stop the beeping, touch and hold RESET/TEST Pad until you hear two beeps. This puts the Performance Control Package in TEST. After the refrigerator reaches a proper and cold enough temperature, return the Control Package to operation scanning by touching the RESET/TEST Pad.



FLASHING TOO WARM Symbol – Means the refrigerator and/or freezer were too warm, but it’s OK now. **Check for possible food spoilage.** To clear the symbol, touch the RESET/TEST Pad.



DOOR OPEN, ALERT



TOO WARM, ALERT



FLASHING TOO WARM, ALERT

The ALERT Symbol comes on when the refrigerator or freezer has been warm for 6 hours or more; there has been an open door for 4 or more hours; or the refrigerator or freezer has been warm for 6 or more hours, but is OK now. **Check for possible food spoilage.**



The CHECK COIL Symbol comes on every two months to remind you to check for dust and lint on the condenser coil behind the base grille. (See page 13 for cleaning instructions.)

To clear the symbol touch the RESET/TEST Pad.

Other combinations of Check Point Display symbols:

The following Display Symbol combinations show the represented conditions if they were in both compartments. If an over-temperature condition occurred in just one compartment, only that compartment's indicator light would appear.



Power is off.



Freezer TOO WARM; time to CHECK COIL.



Refrigerator and/or freezer TOO WARM for 6 or more hours; time to CHECK COIL.



DOOR (or doors) OPEN; refrigerator and/or freezer TOO WARM for 6 or more hours.



DOOR (or doors) OPEN; refrigerator and/or freezer TOO WARM for 6 or more hours; time to CHECK COIL.



DOOR (or doors) OPEN; time to CHECK COIL.



DOOR (or doors) OPEN for 4 or more hours; time to CHECK COIL.



DOOR (or doors) OPEN; refrigerator and freezer TOO WARM.



DOOR (or doors) OPEN; refrigerator and freezer TOO WARM; time to CHECK COIL.



Refrigerator and freezer were TOO WARM; time to CHECK COIL.



DOOR (or doors) OPEN; refrigerator and freezer were TOO WARM.



DOOR (or doors) OPEN; refrigerator and freezer were TOO WARM; time to CHECK COIL.

Adjusting meat pan temperature...

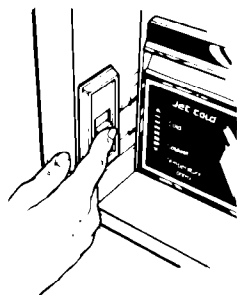

Use Control to Adjust Meat Pan Temperatures

Cold air flows against the meat pan through an opening between the freezer and the refrigerator. This helps keep the meat pan colder than the rest of the refrigerator.

Set the control beside the meat pan to raise or lower the temperature.

Adjusting crisper Humidity Control...

You can control the amount of humidity in the moisture-sealed crisper.

1. The control can be adjusted to any setting between LO and HI.
2. **LO** (open) lets moist air out of crisper for best storage of fruits and vegetables with skins.
3. **HI** (closed) keeps moist air in the crisper for best storage of fresh leafy vegetables.



If moisture builds up in the crisper, move the control to a lower setting.

Adjusting shelves...

Shelves can be adjusted to match the way you use your refrigerator. Glass shelves are strong enough to hold bottles, milk and other heavy food items. *The roll-out shelf should be the bottom shelf in your arrangement.*

To remove glass shelves:

1. Tilt up at front.
2. Lift up at back.
3. Pull shelf straight out.

Glass shelves are heavy. Be careful.

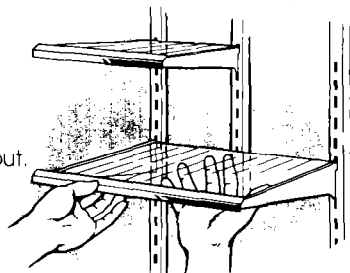

To replace:

1. Guide the rear hooks into the slots in the shelf supports.
2. Tilt up front of shelf until hooks drop into slot. Lower front of shelf to level position.

To remove door shelves:

- Lift up and out

To replace:

- Insert hooks into guides on both sides.
- Push down.

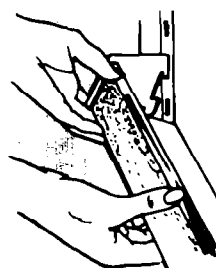

Removing the Roll-Out Shelf...

The tray rests on a frame that slides out for easy loading or unloading. It should be the bottom shelf in your arrangement.

The tray lifts out of the frame. The frame itself is removed and replaced just like the shelves.

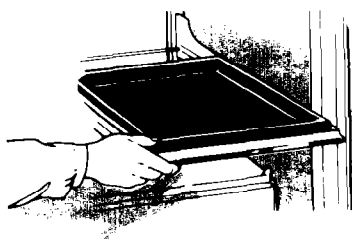

Roll Out the Shelf

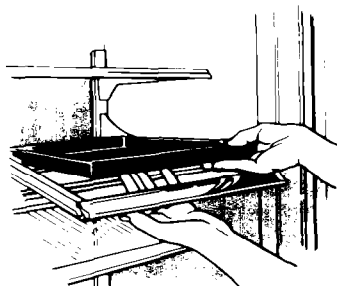

Lift Out the Tray

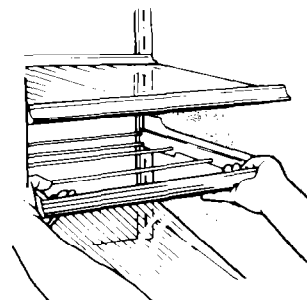

Tilt the Front;
Lift the Back

Removing the crisper, meat pan and covers...

Removing:

1. Slide crisper and meat pan straight out to stop.
2. Lift the front.
3. Slide the rest of the way out.
4. Replace in reverse order.

Replacing:

- Covers are held in place by two pegs at the back and two notched tabs in front.
1. Press front tabs out of the way.
 2. Lift cover front.
 3. Lift back off the pegs.
 4. Replace in reverse order.

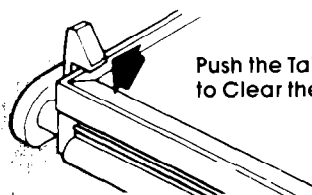

Push the Tab
to Clear the Cover.

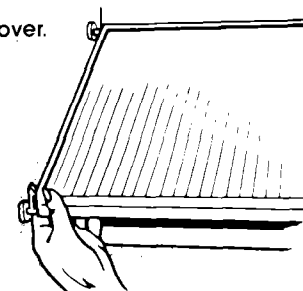

Snap Back Into Place.

Removing freezer shelves...

- Lift front slightly.
- Lift back off supports.
- Replace in reverse order.

Lift the Front
Then the Back

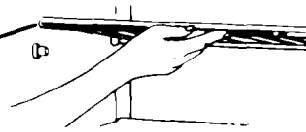

Removing the freezer basket...

For proper air movement, keep the freezer basket in place when the refrigerator is operating.

To remove the basket:

- Slide out to the stop.
- Lift the front to clear the stop.
- Slide out the rest of the way.

To replace the basket:

- Place basket on the slides.
- Make sure the wire stops clear the front of the slides.
- Slide basket in.

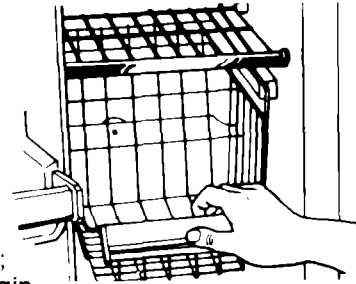

Pull to Stop;
Lift; Pull Again

Cold Water and Ice Dispenser...

FOR ICE:

Press a **sturdy** glass against the ice dispenser bar. (Pressure and tumbling can break a fragile glass.) Remove the glass to stop dispensing.

The first few batches of ice from the ice maker may have a bad taste. Throw them away. This is from new plumbing and parts.

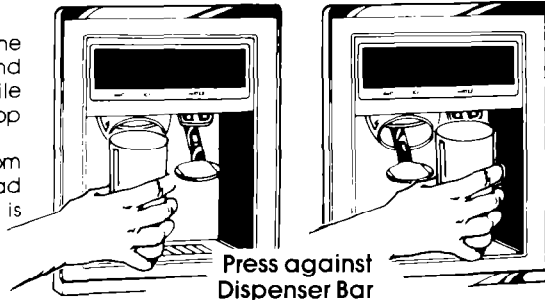

Press against
Dispenser Bar

FOR CHILLED WATER:

Press a **sturdy** glass against the water dispenser bar. (Pressure can break a fragile glass.) Remove the glass to stop dispensing.

If the dispenser is not used regularly, dispense enough every week to freshen the supply. Allow 2-3 hours for chilling.

Ice is dispensed from the ice maker storage bin in the freezer. When the dispenser bar is pressed, a trapdoor opens in a chute between the dispenser and the ice bin. Ice is moved from the bin and falls through the chute. When the dispenser bar is released, a faint buzzing sound may be heard for a few seconds. **Do not connect the ice dispenser to a softened water supply. Water softening chemicals will cause damage to the ice maker mold.**

Chilled water comes from a tank behind the meat pan. It holds about 50 ounces (1.5 L).

When the refrigerator is first hooked up, press the water dispenser with a glass or a jar until you have drawn and discarded 2 or 3 quarts (1.9 to 2.8 L).

Only air will come out to start with. The water you draw and discard will rinse the tank and pipes.

Allow about 24 hours to chill the first tankful.

NOTE: The small tray beneath the dispenser is designed to hold **small** spills. There is no drain in this tray. **Do not pour water into it.** Water from **small** spills will evaporate.

Common Problems

PROBLEM

CAUSE

SOLUTION

Dispenser won't work.

Freezer door open.

- Close the freezer door.

Ice dispenser won't work.

Ice bin not properly installed.
Wrong ice in ice bin.

- Make sure bin is pushed all the way in.
- **Use only ice crescents from ice maker.**
Other shapes won't dispense properly.

Ice dispenser stops working.

Ice dispenser bar held in too long.

- Wait about 3 minutes for the dispenser motor to reset. Large amounts of ice should be taken from the bin, **not through the dispenser.**

Off-taste or odor in ice.

Ice attracts airborne odors.
Old ice.
Water quality.

- Use rapidly or store in covered container.
- Dump old ice and make new supply.
- Water containing minerals (such as sulfur) may require a filter to remove.

Foods not properly wrapped.
Ice bin and freezer may need cleaning.
Plumbing to ice maker.

- Wrap properly. See pages 15 and 16.
- Clean freezer and ice bin. See Cleaning Chart on page 13.
- Follow installation instructions for proper ice maker water supply hook-up.
- The first few loads of ice from a new ice maker may have an off-taste. Dump ice and make new supply.

New ice maker.

Remove and empty the storage bin:

- If the ice dispenser has not, or will not be used for a week or more;
- If a power failure causes ice in the bin to melt and freeze together;
- If the ice dispenser is not used regularly.

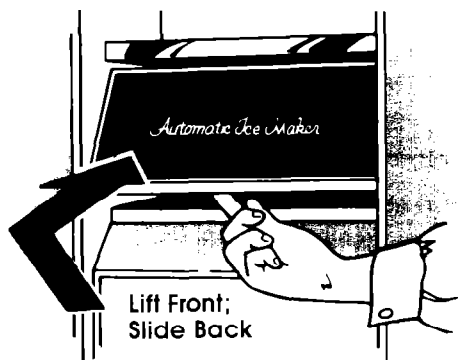

1. Pull the covering panel out from the bottom and slide it to the rear.

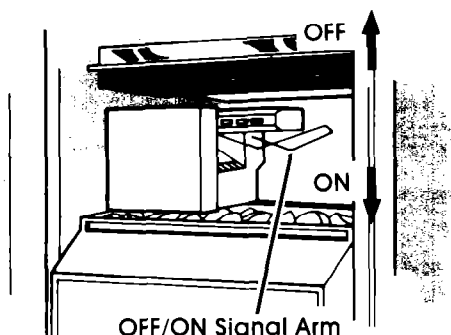

2. Lift the signal arm so it clicks into the OFF position. Ice can still be dispensed, but no more will be made.

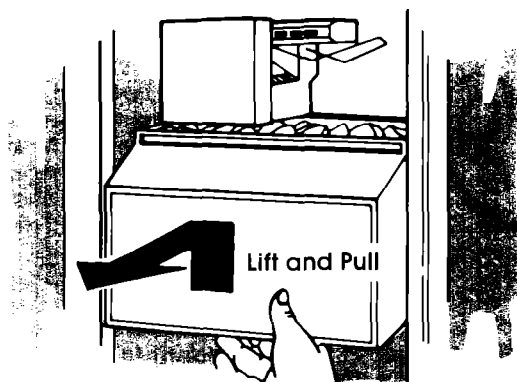

3. Lift the front of the storage bin. Pull it out.
4. Empty the bin. Use hot or warm water to melt the ice if necessary. **Never use anything sharp** to break up ice in the bin. This can damage the bin and dispenser mechanism.
5. Wash with mild detergent. Rinse well. Do not use harsh or abrasive cleansers or solvents.
6. When replacing the bin, make sure it is pushed in all the way. Push the signal arm down to the ON position to restart ice production.

The **night light** uses a heavy-duty 10-watt bulb. When it burns out, purchase another from your dealer. A switch underneath the panel turns the light on and off.

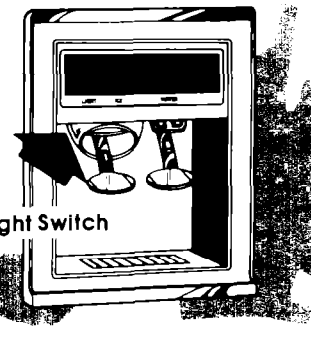

Changing light bulbs...

Before removing a light shield for cleaning or for replacing a bulb, **unplug the refrigerator**. Use *appliance bulbs only*.

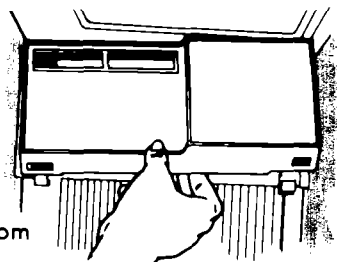

Pull Out at the Bottom

Light bulbs behind refrigerator and freezer control consoles:

- Pull bottom of panel straight out.
- Lift top of panel off supports.
- Replace with a 40-watt appliance bulb.
- Replace panel in reverse order.

• Light bulb behind ice maker:

- Remove the ice bin (see ice maker instructions page 10).
- Replace with a 40-watt appliance bulb.
- Replace ice bin.

• Light bulb above crisper:

- Pull top of the light shield away from the back wall.
- Lift shield off base supports.
- Replace with a 40-watt appliance bulb.
- Replace shield in reverse order.

• Night light in dispenser area: (See above.)

- Reach for the bulb through the dispenser area.
- Replace with a heavy-duty 10-watt bulb.

Sounds you may hear...

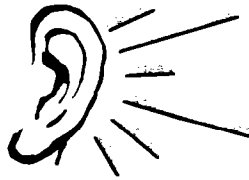

Your new refrigerator may make sounds that your old one didn't. Because the sounds are new to you, you might be concerned about them. Don't be. Most of the new sounds are normal. Hard surfaces like the floor, walls and cabinets can make the sounds seem louder.

The following chart describes the kinds of sounds that might be new to you, and what may be making them.

Possible Sounds:

- **Slight Hum, Soft Hiss:**
- **Water Sounds:**
- **Ice Maker Sounds:**
 - trickling water
 - thud (clatter of ice)
- **Running Sounds:**
- **Beeping Sounds:**

Probable Causes:

Your refrigerator has two fans; you may hear the fan motors and moving air. When the refrigerator stops running, you may hear gurgling in the tubing for a few minutes after it stops. You may also hear defrost water running into the defrost water pan. When the ice maker is running, you may hear a buzzing (from the water valve), trickling water and the clatter of ice dumped into the bin. Your refrigerator has a high-efficiency compressor and motor. It will run longer than older designs. It may even seem to run most of the time. The SYSTEMS SENTINEL® II Performance Control Package is designed to make a beeping sound when something is not as it should be, or when a control pad is touched. See pages 6 and 7 for more information.

Energy saving tips...

You can help your refrigerator use less electricity.

- Check door gaskets for a tight seal. Level the cabinet to be sure of a good seal.
- Clean the condenser coil regularly.
- Open the door as few times as possible. Think about what you need before you open the door. Get everything out at one time. Keep foods organized so you won't have to search for what you want. Close door as soon as food is removed.
- Go ahead and fill up the refrigerator, but don't overcrowd it so air movement is blocked.
- It is a waste of electricity to set the refrigerator and freezer to temperatures colder than they need to be. If ice cream is firm in the freezer and drinks are as cold as your family likes them, that's cold enough.
- Keep the Power Saving Control on OFF unless moisture forms on the refrigerator exterior.
- Make sure your refrigerator is not next to a heat source such as a range, water heater, furnace, radiator, or in direct sunlight.

Cleaning your refrigerator...

Both the refrigerator and freezer sections defrost automatically. But both should be cleaned about once a month to help prevent odors from building up. Of course, spills should be wiped up right away.

To clean your refrigerator, turn the Refrigerator Control to OFF, unplug it, take out all removable parts, and clean it according to the following directions.

Removing the base grille...

- Open the doors.

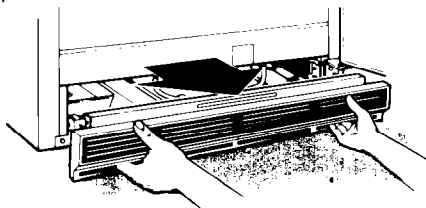

- Pull grille outwards as shown.
- **Do not remove Tech sheet** fastened behind grille.

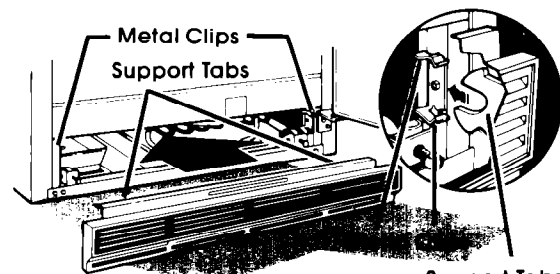

To replace:

- Line up grille support tabs with metal clips.
- Push firmly to snap into place.
- Close the doors.

Cleaning chart...

Part	What to use	How to clean
Removable parts (shelves, crisper, meat pan etc.)	Mild detergent and warm water.	<ul style="list-style-type: none"> • Wash removable parts with warm water and a mild detergent. • Rinse and dry.
Outside	Sponge, cloth or paper towel; mild detergent; appliance wax (or good auto paste wax).	<ul style="list-style-type: none"> • Wash with warm water and a mild detergent. Do not use abrasive or harsh cleansers. • Rinse and dry. • Wax painted metal surfaces at least twice a year with appliance wax or a good auto paste wax. Apply wax with a clean, soft cloth. Do not use wax on plastic parts. <p style="text-align: center;">Waxing painted metal surfaces provides rust protection.</p>
Inside walls (Freezer should be allowed to warm up so cloth won't stick.)	Sponge, soft cloth or paper towel, baking soda, warm water, mild detergent.	<ul style="list-style-type: none"> • Wash with warm water and – mild detergent or – baking soda (2 tablespoons [26 g] to 1 quart [.95 l] warm water. • Rinse and dry.
Door liners and gaskets	Sponge, soft cloth or paper towel; mild detergent, warm water.	<ul style="list-style-type: none"> • Wash with mild detergent and warm water. • Rinse and dry. <p style="text-align: center;">DO NOT USE Cleaning waxes, concentrated detergents, bleaches or cleansers containing petroleum on plastic parts.</p>
Dark plastics (covers and panels)	Mild detergent and warm water; soft, clean sponge and soft, clean cloth.	<ul style="list-style-type: none"> • Wash with a soft grit-free cloth or sponge. • Rinse and dry with a damp grit free cloth or chamois. <p style="text-align: center;">DO NOT USE paper towels, window sprays, scouring cleansers, or flammable or toxic solvents like acetone, gasoline, carbon tetrachloride, etc. These can scratch or damage the material.</p>
Defrost pan	Warm water and mild detergent.	<ul style="list-style-type: none"> • Remove base grille. (See page 12.) • To remove defrost pan, lift pan over wire brace (remove tape; if any). • Wash defrost pan with warm water and mild detergent. • Rinse and dry. • Replace with notched corner to the rear. • Push it all the way in. • Make sure defrost drain tube is pointing into pan. • Replace base grille.
Condenser Coil	Vacuum cleaner; using the extended narrow attachment.	<ul style="list-style-type: none"> • Remove base grille. • Clean dust and lint from condenser when CHECK COIL Symbol glows (every 2 months). • Replace base grille.
Floor under refrigerator	Usual floor cleaners.	<ul style="list-style-type: none"> • Roll refrigerator out only as far as water supply line allows. • Wash floor. • Roll refrigerator back. • Check to see if the refrigerator is level.

SOUNDS YOU MAY HEAR

ENERGY SAVING TIPS

CLEANING

Food storage guide

STORING FRESH FOOD



There is a right way to package and store refrigerated or frozen foods. To keep foods fresher, longer, take the time to study these recommended steps.

Leafy Vegetables ...Remove store wrapping. Trim or tear off bruised and discolored areas. Wash in cool water, drain and store in crisper. Cold, moist air helps keep leafy vegetables fresh and crisp. The crisper has sealing gaskets to help keep humid air in. It also has a control to help adjust the amount of humidity in the crisper.

Vegetables with Skins (carrots, peppers)...Store in crisper, plastic bags or plastic container.

Fruits ...Wash, let dry and store in refrigerator in plastic bags or crisper. Do not wash or hull berries until they are ready to use. Sort and keep berries in their store container in a crisper, or store in a loosely closed paper bag on a refrigerator shelf.



Meat* ... Meat is perishable and expensive...you won't want to waste an ounce of it through careless handling. The following list and chart give you packaging hints and time limits. Store meat in the meat pan.

Fresh, Prepackaged Meat. Store fresh meat in the store wrapping. Vacuum packaged meat can be frozen for as long as one month if the seal is not broken. If you want to keep it frozen longer, you should wrap it with special freezer wrapping material.

Fresh Meat, Not Prepackaged. Remove the market wrapping paper and re-wrap in plastic wrap or aluminum foil for storing it unfrozen.

Cooked Meat. Wrap or cover cooked meat tightly with plastic wrap or aluminum foil. Store immediately.

Cured or Smoked Meat and Cold Cuts. Ham, bacon, sausage, cold cuts, etc., keep best in original wrappings. Once opened, tightly re-wrap in plastic wrap or aluminum foil.

Canned Ham. Store in refrigerator unless the label says it's okay to store on the shelf. Do not freeze.

Fresh Poultry. Wrap in aluminum foil or plastic wrap. The plastic wrap on poultry, as purchased, may be used for storage.

STORAGE CHART FOR FRESH AND CURED MEAT*

Type	Approximate Time (days)
Variety Meats	1 to 2
Chicken	1 to 2
Ground Beef	1 to 2
Steaks and Roasts	3 to 5
Cured Meats	7 to 10
Bacon	5 to 7
Cold Cuts	3 to 5

*If meat is to be stored longer than the times given, follow the directions for freezing.

NOTE: Fresh fish and shellfish should be used the same day as purchased.

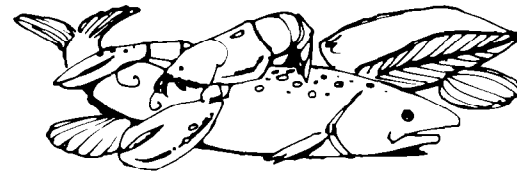

Eggs ... Store without washing in the original carton or use the Utility Bin that came with your refrigerator.

Milk...Wipe milk cartons. For best storage, place milk on interior shelf or bottom door shelf.

Beverages...Wipe bottles and cans. Store on a door shelf or inside the refrigerator.

Butter...Keep opened butter in covered dish or in the Utility Compartment. When storing an extra supply, wrap in freezer packaging and freeze.

Cheese ...Store in the original wrapping until you are ready to use it. Once opened, re-wrap tightly in plastic wrap or aluminum foil.

Condiments ...Store small jars and bottles (cat-sup, mustard, jelly, olives) on the door shelves where they are in easy reach.

Leftovers...Cover leftovers tightly with plastic wrap or aluminum foil to keep food from drying out and transferring food odors. Plastic containers with tight lids are fine, too.

FREEZING & STORING FROZEN FOODS

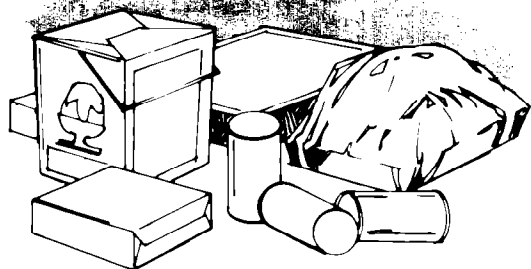

The freezer section is designed for storage of commercially frozen foods and for freezing foods at home.

Packaging – The secret of successful freezing is in the packaging. The wrap you use must be air, moisture and vapor proof. The way you close and seal the package must not allow air, moisture or vapor in or out. Packaging done in any other way could cause food odor and taste transfer throughout the refrigerator and drying out of the frozen food.

Rigid polyethylene (plastic) containers with tight-fitting lids, straight-sided canning/freezing jars, heavy-duty aluminum foil, plastic-coated paper and non-permeable plastic wraps (such as saran) are recommended. Note: Heat-sealed boiling bags are easy to use and can be used by themselves or as carton liners.

Sealing – When sealing foods in bags **squeeze out the air** (liquids need headspace to allow for expansion.) Twist the top and turn it back. Fasten tie securely around the doubled-over tail. Put the label inside transparent bags; use self-adhesive label on outside of opaque ones.

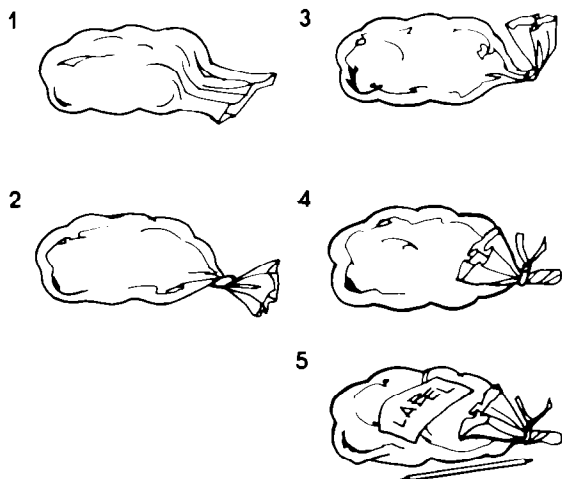

Air-tight wrapping calls for “drugstore” wrap. Cut the sheet about one-third longer than the distance around the food. Bring the ends together and fold in (toward the food) at least twice to seal out air. Crease ends close to food, press air from package. Fold tips

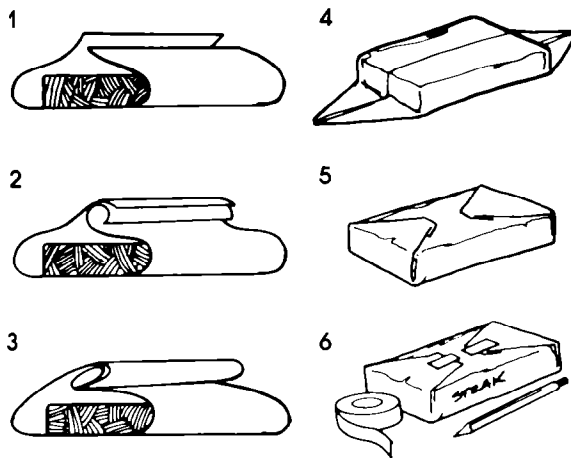

over twice. Finish package and tape closed. NOTE: With unboned meats, pad sharp edges with extra wrap or use stockinette to protect the wrap from punctures.

DO NOT USE:

- Bread wrappers
- Non-polyethylene plastic containers
- Containers without tight lids
- Waxed paper
- Waxed-coated freezer wrap
- Thin, semi-permeable wrap

None of these are totally moisture, air or vapor proof. **The use of these wrappings could cause food odor and taste transfer and drying out of the frozen food.**



Freezing Fruits – Select ripe, blemish-free fruits. Be sure they taste as good as they look. Wash 2 to 3 quarts (liters) at a time and drain. Fruit that stands in water may lose food value and become soggy. Sort, peel, trim, pit and slice as needed.

Pack in rigid wide-mouthed containers or other recommended material. Leave head space to allow liquids to expand during freezing.



Freezing Vegetables – Freeze only fresh high-quality vegetables picked when barely mature. For best results, freeze no more than 2 to 3 hours after picking. Wash in cold water, sort and cut into appropriate sizes. Blanch or scald. Pack in recommended container and freeze.

Do not freeze lettuce, celery, carrot sticks, potatoes or fresh tomatoes. All will become limp or mushy. Tomatoes will collapse when thawed.



Freezing Meats – The meat you thaw can only be as good as the meat you freeze. "Drugstore" wrap in meal-size packages. Flat cuts or patties should be wrapped individually or in layers separated by a double thickness of freezer wrap.

Make sure store wrappings are moisture and vapor proof. If not, re-wrap meats with one of the wraps recommended under "Packaging".



Freezing Cooked Food – Prepare cooked foods as you would for the table; shorten cooking time 10 to 15 minutes to allow for additional cooking during reheating. Omit seasonings and part of the liquid. Plan to add them at reheating time. Potatoes should also be added to soup and stew at heating time. Add crumb and cheese toppings at heating time.

Cool as rapidly as possible and freeze at once. Liquid or semi-liquid dishes may be frozen in recommended containers with *head-space*. Casseroles and other more solid foods may be frozen in the baking container. If you don't want to leave your casserole dish in the freezer, line it with foil. Bake, cool, freeze, lift out the foil package, bag it and return to freezer.

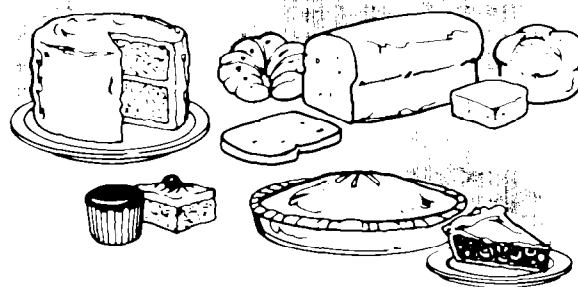

Freezing Baked Goods – Wrap baked breads in recommended material. Thaw in wrapping. Unbaked yeast breads can be frozen after the first rising. Punch down, shape into loaves, wrap and freeze.

Bake cookies as usual. Cool and freeze on trays, then pack in recommended freezer bags or cartons. Unbaked cookies may be dropped, molded or rolled and frozen on cookie trays. Store in bag or carton; bake without thawing. Refrigerator-type cookies can be wrapped and frozen in roll form. Thaw only enough to slice when ready to bake.

Fruit pies are best frozen unbaked. Bake without thawing. Bake pecan and similar pies before freezing...rich fillings do not freeze solid. Cut steam vents in top crusts when ready to bake.

IMPORTANT: Do not expect your freezer to quick-freeze any large quantity of food. Put no more unfrozen food into the freezer than will freeze within 24 hours. (No more than 2 to 3 pounds of fresh meat or 3 to 4 pounds of vegetables per cubic foot of freezer space.) Leave enough space for air to circulate around packages. Be careful to leave enough room at the front so the door can close tightly.

FOOD STORAGE CHART

Storage times* will vary according to the quality of the food, the type of packaging or wrap used (moisture and vapor-proof), and the storage temperature which should be 0° F (-17.8°C).

Food	Storage time
FRUITS	
Fruit juice concentrate	12 months
Commercially frozen fruit	12 months
Citrus fruit and juices	4 to 6 months
Others	8 to 12 months
VEGETABLES	
Commercially frozen	8 months
Home frozen	8 to 12 months
MEAT	
Bacon	4 weeks or less
Corned beef	2 weeks
Cured ham	1 to 2 months
(Salting meat shortens freezer life)	
Frankfurters	1 month
Ground beef, lamb, veal	2 to 3 months
Roasts:	
Beef	6 to 12 months
Lamb and veal	6 to 9 months
Pork	4 to 8 months
Sausage, fresh	1 to 2 months
Steaks and chops:	
Beef	8 to 12 months
Lamb, veal, pork	3 to 4 months
FISH	
Cod, flounder, haddock	
Sole	6 months
Blue fish, salmon	2 to 3 months
Mackerel, perch	2 to 3 months
Breaded fish (purchased)	3 months
Clams, oysters, cooked	
fish, crab, scallops	3 to 4 months
Alaskan king crab	10 months
Shrimp, uncooked	12 months
POULTRY	
Whole chicken or turkey	12 months
Duck	6 months
Giblets	2 to 3 months
Cooked poultry w/gravy	6 months
Slices (no gravy)	1 month

Food	Storage time
MAIN DISHES	
Stews; meat, poultry	
and fish casserole	2 to 3 months
TV dinners	3 to 6 months
DAIRY PRODUCTS	
Butter	6 to 9 months
Margarine	2 to 9 months
Cheese:	
Camembert, brick,	
Mozzarella, farmer's	3 months
Creamed cottage	DO NOT FREEZE
Cheddar, Edam, Gouda,	
Swiss, etc.	6 to 8 weeks
Freezing can change texture of cheese.	
Ice cream, ice milk	
sherbet	4 weeks

EGGS	
Whole (mixed)	9 to 12 months
Whites	9 to 12 months
Yolks	9 to 12 months
(Add sugar or salt to yolks or whole mixed eggs)	

BAKED GOODS	
Yeast breads and rolls	3 months
Baked Brown 'N Serve	
rolls	3 months
Unbaked breads	1 month
Quick breads	2 to 3 months
Cakes, unfrosted	2 to 4 months
Cakes, frosted	8 to 12 months
Fruit cakes	12 months
Cookie dough	3 months
Baked cookies	8 to 12 months
Baked pies	1 to 2 months
Pie dough only	4 to 6 months

*Based on U.S.D.A. and Michigan Cooperative Extension Service suggested storage times.

If electricity goes off

Ask the power company how long it will be off.

- If service is to be interrupted less than 24 hours, **keep the doors closed.** Most food will stay frozen.
- If service is to be interrupted more than 24 hours:
 - Store all frozen food in a frozen food locker.
 - Or...**
 - Place 2 lbs. (0.9 kg) of dry ice in freezer for every cu. ft. of freezer space. This will keep frozen foods for 2 to 4 days. Wear gloves for protection.
 - If neither food storage locker nor dry ice is available, use or can perishable food at once.
- A full freezer will stay cold longer than a partly filled one. Meat stays colder longer than baked goods. If food contains ice crystals, it may be safely refrozen, although the quality and flavor may be affected. Use refrozen foods first. If you have any doubts about the condition of the food, dispose of it.
- When the power comes back on, the TOO WARM Symbol may come on. See pages 6 and 7 for information on these.

Vacation and moving care



Short vacations. . .

No need to shut off the refrigerator if you will be away for less than four weeks. Use up perishables; freeze other items. Turn off your ice maker, shut off the water supply; empty the ice bin and make sure all ice crescents are dispensed out of the mechanism.

Long vacations. . .

Remove all the food if you are going for a month or more. At least a day ahead, turn off the water supply to the ice maker. When the last load of ice drops, turn off the ice maker.

Unplug the refrigerator and clean it...rinse well and dry. Tape rubber or wood blocks to both doors...keeping them open far enough for air to get in. This will keep odor and mold from building up.

Tape the blocks out of a child's reach... do not allow children near the refrigerator when the doors are blocked open.

To restart refrigerator, see instructions on page 4.

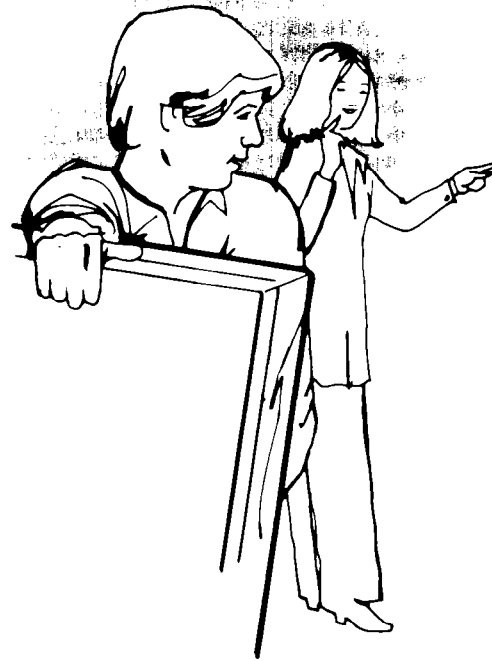

Moving...

Shut off the ice maker water supply a day ahead of time. Disconnect the water line. After the last supply of ice drops, turn off the ice maker.

Remove all food. Pack frozen foods in dry ice. Unplug the refrigerator and clean it thoroughly. Remove everything that comes out. Wrap all parts well and tape them together so they don't shift and rattle.

Also, remove the water supply tank behind the meat pan by:

1. Disconnecting water inlet and outlet tubes at the top of the tank.
2. Removing three mounting screws from the tank.
3. Draining the tank.

Re-install the empty tank, and remember to check for tight water connections when the refrigerator is hooked up at your new location.

Screw in the levelling rollers; tape the doors shut; tape the electric cord to the cabinet. When you get to your new home, put everything back, level it, reconnect the water supply and refer to page 4.

QUESTIONS?

...call your
COOL-LINE®
service
assistance
telephone
number
(page 19).



If you need service or assistance, we suggest you follow these four steps:

1. Before calling for assistance...

Performance problems often result from little things you can find and fix yourself without tools of any kind.

If your refrigerator will not operate:

- Is the electric cord plugged in?
- Is a fuse blown or a circuit breaker tripped?
- Is the Refrigerator Control turned ON?

If your ice maker will not work:

- Has the freezer had enough time to get cold? With a new refrigerator, this might take overnight.
- Is the signal arm ON...in the down position?
- Is the water valve turned on, and is water getting to the ice maker?

If there is a Beeping Sound:

- The SYSTEMS SENTINEL® II Performance Control Package makes beeping sounds when...
 - a Control Pad is touched.
 - the Control Package is alerting you of a problem. Check the display for an existing condition. **Ex.** If the refrigerator is warm from the door being open, the TOO WARM and DOOR OPEN symbols will appear in the display.

If there is a rattling or jingling noise, or other unfamiliar sounds:

- Is something on top or behind the refrigerator making noise when the refrigerator is running?
- New features on your refrigerator make new sounds. You may hear air flowing from the fan, timer clicks for the defrosting cycle, defrost water dripping into the defrost pan, or water filling the molds and ice dropping into the bin.

If there is water in the defrost pan:

- In hot, muggy weather, this is normal. The pan can even be almost full. Make sure the refrigerator is level so the pan doesn't overflow.

If the lights aren't working:

- Check fuses and circuit breakers. Make sure it's plugged in.

If a bulb is burned out:

- See instructions for changing light bulbs on page 11. Use appliance bulb only.

If the motor seems to run too much:

- Is the condenser, behind the base grille, free of dust and lint?
- On hot days, or if the room is warm, the motor naturally runs longer.
- If the door has been opened a lot, or if a large amount of food has been put in, the motor will run longer to cool down the interior.

Remember: Motor running time depends on different things: number of door openings, amount of food stored, temperature of the room, setting of the controls.

And, your new refrigerator may be larger than your old one so it has more space to be cooled. It also has a regular freezer instead of a frozen food compartment. All this means better refrigeration and may require more running time than your old one.

2. If you need assistance* ...

Call Whirlpool COOL-LINE® service assistance telephone number. Dial free from:

Continental U.S. (800) 253-1301
Michigan (800) 632-2243
Alaska & Hawaii (800) 253-1121

and talk with one of our trained Consultants. The Consultant can instruct you in how to obtain satisfactory operation from your appliance or, if service is necessary, recommend a qualified service company in your area.

3. If you need service* ...

Whirlpool has a nationwide network of franchised TECH-CARE® Service Companies. TECH-CARE service technicians are trained to fulfill the product warranty and provide after-warranty service, anywhere in the United States. To locate

TECH-CARE service in your area, call our COOL-LINE service assistance telephone number (see Step 2) or look in your telephone directory Yellow Pages under:

APPLIANCES - HOUSEHOLD -
MAJOR - SERVICE & REPAIR

WHIRLPOOL APPLIANCES
FRANCHISED TECH-CARE SERVICE

SERVICE COMPANIES
XYZ SERVICE CO
123 Maple 999-9999

ELECTRICAL APPLIANCES -
MAJOR - REPAIRING & PARTS

WHIRLPOOL APPLIANCES
FRANCHISED TECH-CARE SERVICE

SERVICE COMPANIES
XYZ SERVICE CO
123 Maple 999-9999

OR

WASHING MACHINES, DRYERS
& IRONERS - SERVICING

WHIRLPOOL APPLIANCES
FRANCHISED TECH-CARE SERVICE

SERVICE COMPANIES
XYZ SERVICE CO
123 Maple 999-9999

4. If you have a problem* ...

Call our COOL-LINE service assistance telephone number (see Step 2) and talk with one of our Consultants, or if you prefer, write to:

Mr. Robert F. Gunts, Vice President
Whirlpool Corporation
Administrative Center
2000 US-33 North
Benton Harbor, MI 49022

*If you must call or write, please provide: model number, serial number, date of purchase, and a complete description of the problem. This information is needed in order to better respond to your request for assistance.



FSP is a registered trademark of Whirlpool Corporation for quality parts. Look for this symbol of quality whenever you need a replacement part for your Whirlpool appliance. FSP replacement parts will fit right and work right, because they are made to the same exacting specifications used to build every new Whirlpool appliance.

VACATION AND MOVING CARE

IF YOU NEED SERVICE OR ASSISTANCE



Making your world a little easier.

Part No. 943599
©1985 Whirlpool Corporation

Printed in U.S.A.

Ice Makers, Dishwashers, Built-In Ovens and Surface Units, Ranges, Microwave Ovens, Trash Compactors, Room Air Conditioners, Dehumidifiers, Automatic Washers, Clothes Dry

